

48XX Series

Ultra-fast Responding, Compact, Thermal Mass Flow Controllers & Meters



Model 4850

The Brooks 48xx Series features a broad flow range, compact size, a variety of analog and digital I/O options, a MEMS-based sensor that provides lightning fast response times, and many other benefits for a variety of applications. The 48xx Series of mass flow controllers and mass flow meters is fully RoHS compliant and is an excellent choice for measurement and control of many common gases including air, N₂, O₂, Ar, He, H₂, CO₂, CO, N₂O, CH₄, C₃H₆ (Propene), and C₃H₈. The optional Local Operator Interface (LOI) provides a convenient user interface to view, control, and configure the 48xx Series devices eliminating the need for remote secondary electronics.

The 48xx Series MEMS-based sensor provides lightning fast response times.

The 48xx Series utilizes a Micro Electro Mechanical System (MEMS) based thermal sensor. Similar to typical thermal sensors, it measures a change in temperature to determine mass flow rate. The difference is that gas flows directly across the sensor, achieving extremely fast response times.

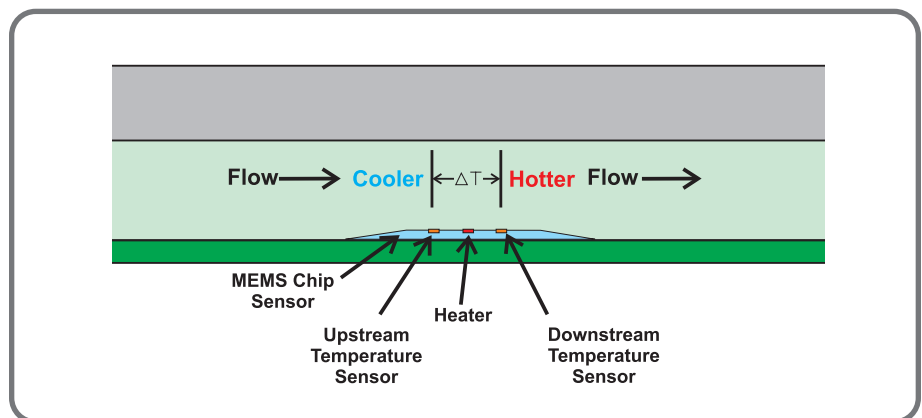

Figure 1 Gas Flow Across the MEMS Sensor

View 48XX Series Product Page

Fast settling times and stable control come standard with the 4850 controller.

The Model 4850 controller uses a proprietary PID algorithm to optimize the control valve response to ensure rapid settling times. The 4850 controller can be counted on to quickly match actual mass flow to any changes in setpoint.

Good things come in small packages.

The MEMS sensor enables a dramatic reduction in size compared to traditional thermal mass flow controllers and thermal mass flow meters. In fact the compact size of the 48xx Series 1" x 3" x 4" (25mm x 76mm x 101mm) takes up less than half the space of typical thermal mass flow controllers.

The 48xx Series is ideal for OEMs.

The broad flow range, fast response time and compact size make for a perfect fit in any OEM system where gas flow needs to be measured or controlled. You can download a free LabView VI to monitor and zero the device.

The Local Operator Interface (LOI) simplifies set-up and operation.

The LOI mounts securely on top of the 48xx Series device. With status LEDs and a large backlit LCD it provides a convenient user interface to view, control and configure the Brooks 48xx Series thermal mass flow devices. This option also allows the user to power the device with a simple power adapter that plugs right in to the wall.

RoHS compliant

Fully RoHS compliant per EU Directive 2011/65/EU.

Variety of input/output options.

The 48xx Series thermal mass flow controllers and thermal mass flow meters come standard with voltage or current and RS232 I/O.

Easily integrated into modular gas delivery systems

The 48xx Series is available with downport connections making it easy to integrate into modular gas delivery systems.

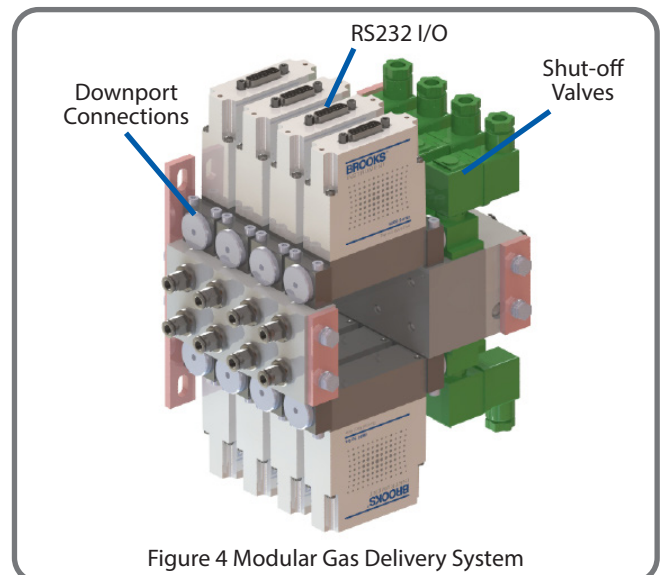
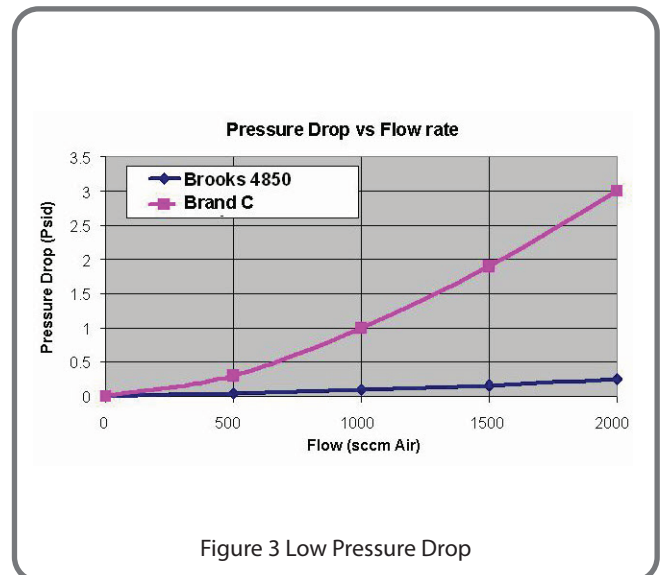
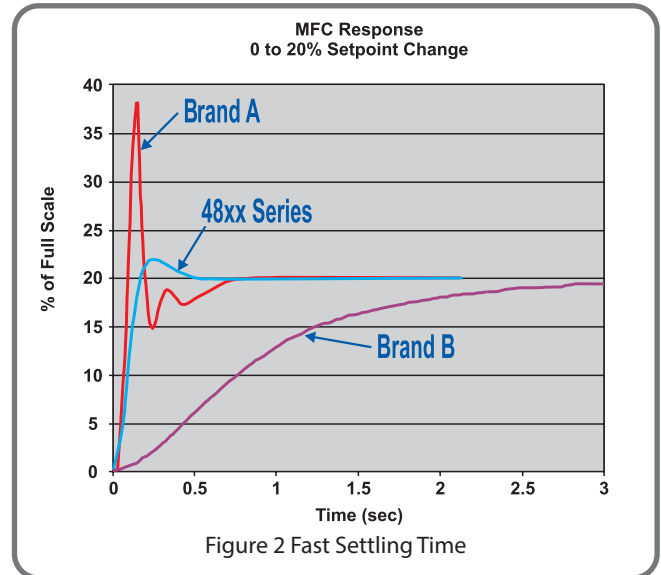

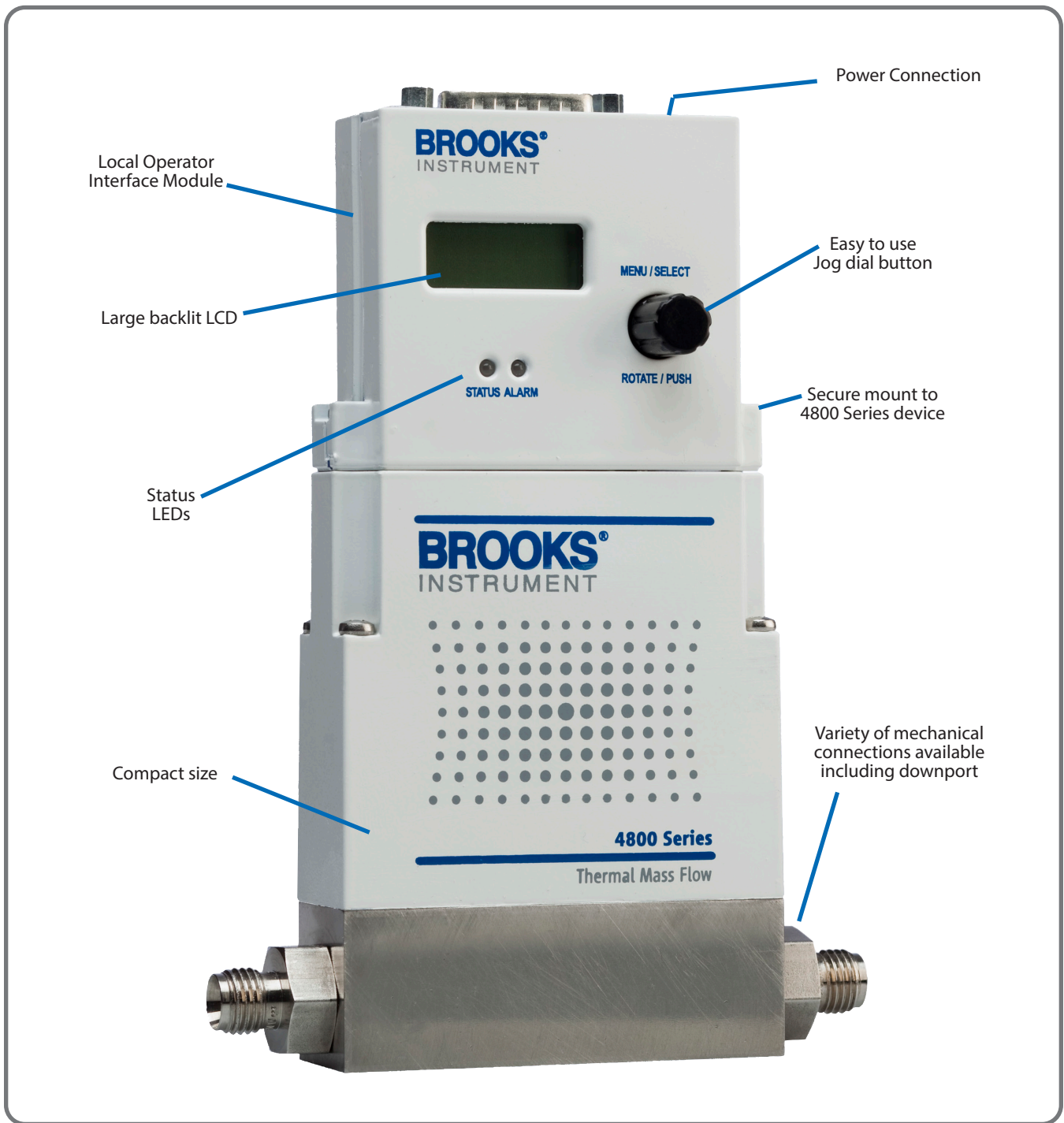

Figure 5 48xx Series with Local Operator Interface

Features	Benefits
Fast response time	Ensure rapid step during process recipe changes
Compact size	Reduces space and eases installation
Optional Local Operator Interface (LOI)	Provides a turnkey solution for local indication, set point control and device configuration eliminating the need for remote secondary electronics
Low pressure drop across the sensor	Provide flow measurement with minimal pressure budget
Variety of analog and digital I/O	Easily aligns with user requirements
Fully RoHS compliant	Meets emerging environmental requirements

PERFORMANCE																									
Full Scale Flow Range	50 ml/min - 40 l/min (50 sccm - 40 slpm) (N ₂ eq., at 0°C Ref, with typical 50 psid pressure differential)																								
Control Range	2 - 100%																								
Flow Accuracy	+/- 3.0% of FS, +/- 1.0% FS optional																								
Flow Repeatability	+/- 0.15% of FS																								
Response Time	Flow signal: <0.3 sec Flow control: Settling time <0.75 sec from 0 to 100% FS (typical <0.5 sec for all steps)																								
Temperature Coefficient	+/- 0.1% of FS/°C (N ₂)																								
RATINGS																									
Gases	Air, N ₂ , O ₂ , Ar, He, H ₂ , CO ₂ , CO, N ₂ O, CH ₄ , C ₃ H ₆ (Propene), C ₃ H ₈ (other gases upon request)																								
Operating Limits	Pressure 0 - 10 barg (0 - 150 psig) Temperature 0 - 50°C Humidity 5 to 95% R.H. (ambient)																								
Differential Pressure Range (Controllers)	Minimum: 0.35 bar (5 psid) Maximum: 10 bar (150 psid)																								
Leak Integrity	Inboard to Outboard: 1x10 ⁻⁹ atm scc/sec Helium max.																								
MECHANICAL																									
Materials of Construction	Wetted parts: stainless steel, fluoroelastomers, silicon-based sensor																								
RoHS	Fully RoHS compliant per EU Directive 2011/65/EU																								
Outline Dimensions	Refer to Figures 6 and 7																								
Process Connections	Inlet/Outlet threads: 9/16" - 18 UNF threads, Refer to Figure 6 for available process connections.																								
ELECTRICAL																									
Electrical Connections	15-pin D-sub connector Analog/RS232: 15-pin D-sub connector																								
Power Supply Voltage**	+15 Vdc + 10% or +24 Vdc + 10% Device only uses single sided power supply Inrush current: < 1 A																								
Power Requirements	<table border="1"> <thead> <tr> <th>Model</th> <th>Device</th> <th colspan="2">15 Vdc</th> <th colspan="2">24 Vdc</th> </tr> <tr> <th></th> <th>Type</th> <th>Typical (mA)</th> <th>Max (mA)</th> <th>Typical (mA)</th> <th>Max (mA)</th> </tr> </thead> <tbody> <tr> <td>4850</td> <td>Controller</td> <td>130</td> <td>160</td> <td>150</td> <td>200</td> </tr> <tr> <td>4860</td> <td>Meter</td> <td>30</td> <td>60</td> <td>30</td> <td>60</td> </tr> </tbody> </table>	Model	Device	15 Vdc		24 Vdc			Type	Typical (mA)	Max (mA)	Typical (mA)	Max (mA)	4850	Controller	130	160	150	200	4860	Meter	30	60	30	60
Model	Device	15 Vdc		24 Vdc																					
	Type	Typical (mA)	Max (mA)	Typical (mA)	Max (mA)																				
4850	Controller	130	160	150	200																				
4860	Meter	30	60	30	60																				
Analog Input/Output	0-5 Vdc or 4-20 mA																								
Digital Input/Output	RS232 (Standard with all analog I/O options)																								
Valve Override Signal	Valve Controller: Input Open Valve Closed: <0.3 V; open valve: >4.8 V																								

** For high flows and/or low differential pressures (using orifices 0.049" (1.25mm) or 0.079" (2.0mm)) only 24 Vdc power is available.

LOCAL OPERATOR INTERFACE (LOI)	
Display	Effective display area: 28mm wide, 11mm high Display Contents: 8x2 dot matrix display
Operating Limits	Temperature 0-50°C Operating Humidity 5 to 95% R.H. (ambient)
Electrical Connections	2 15-pin D-sub connectors, one for the connection to the 48xx Series and one for the remote connection
Power Supply Voltage	The LOI optionally includes a wall mount power adaptor with a 3.5-mm DC-plug. The adaptor works with input voltages of AC 90-240 V/47-63Hz. The adaptor supports European, U.K., Australia and U.S. wall plugs. Power can also be supplied by a remote connection via the D-connector.
Materials of Construction	Enclosure: ABS plastic with CU-Ni plating
RoHS	Fully RoHS compliant per EU Directive 2011/65/EU.
Outline Dimensions	Refer to Figure 8

Product Dimensions 48xx Standard Process and Downport Connections

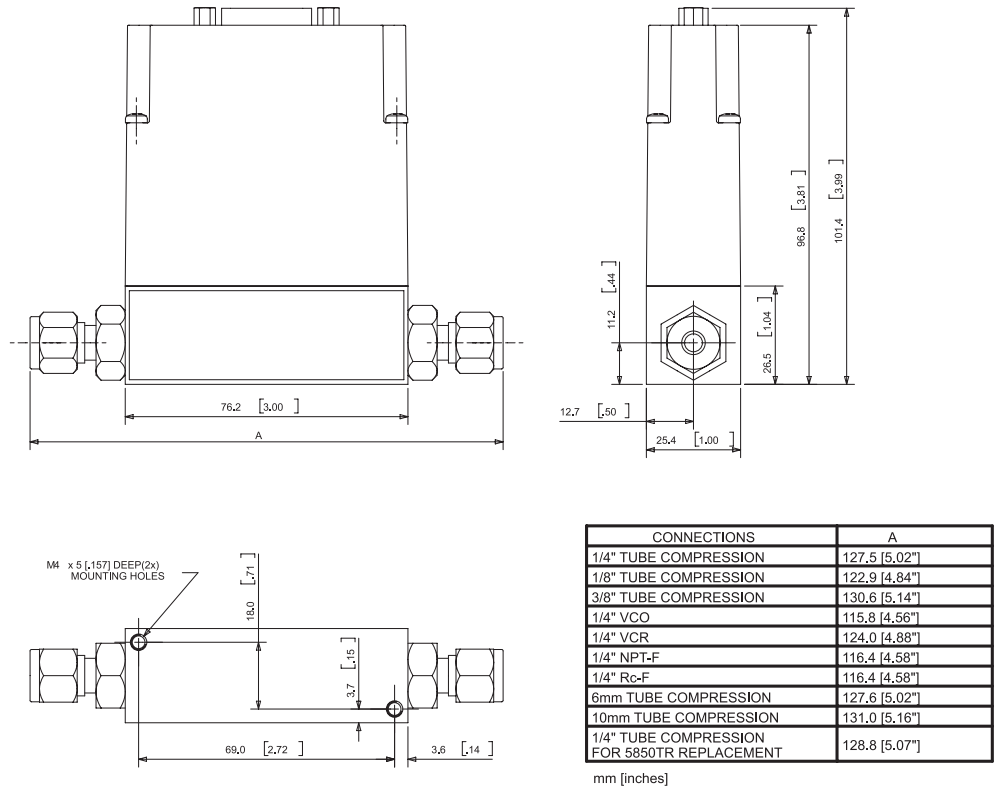

Figure 6 Dimensions for 48xx Series Devices with Standard Process Connections

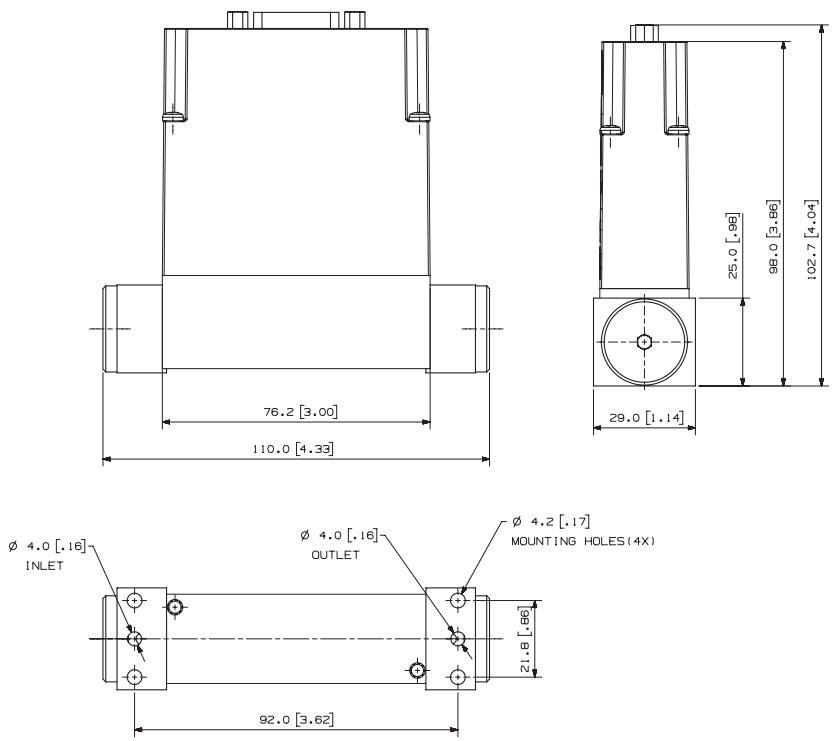

Figure 7 Dimensions for 48xx Series Devices with Downport Connections

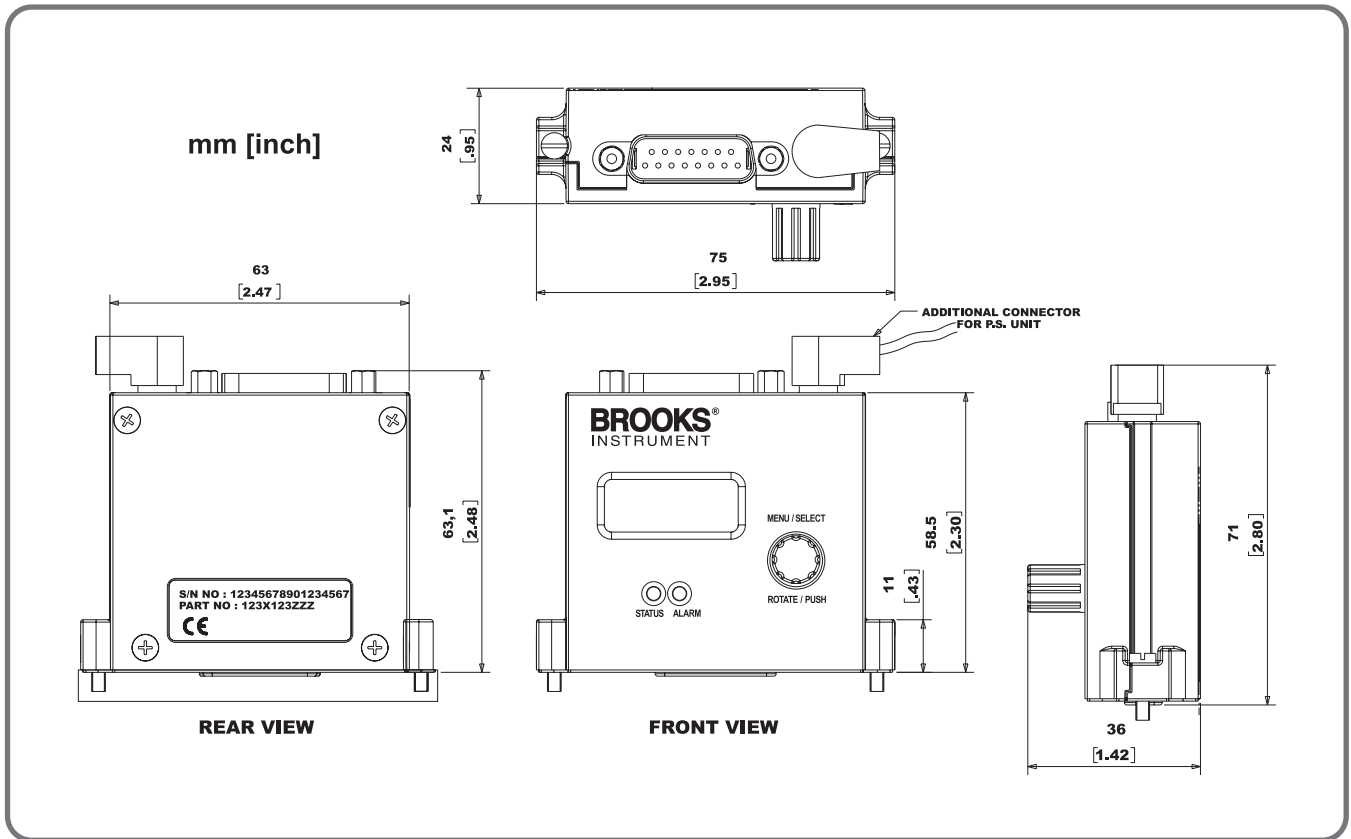
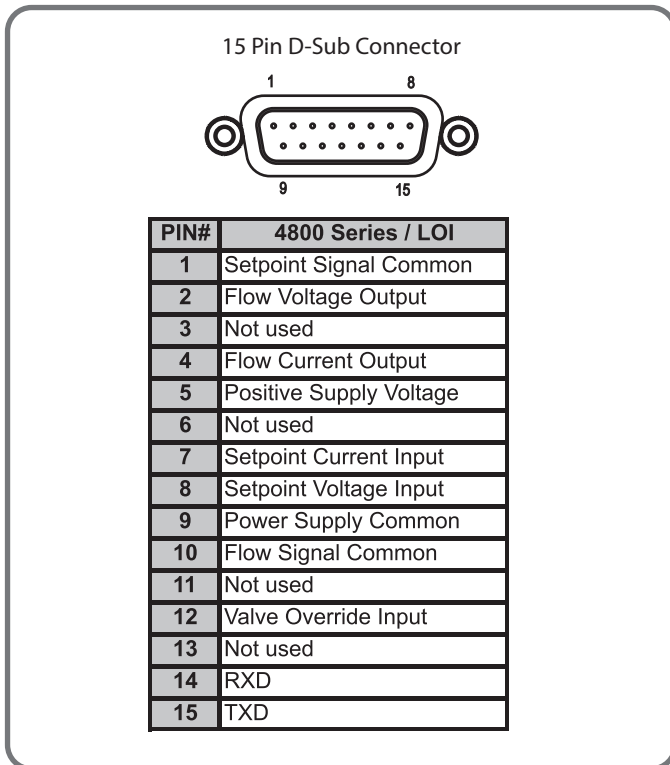





Figure 8 Dimensions for 48xx Series LOI Module

Table 1 48xx Series Pin-Out Diagram



Access our library of CAD Drawings

These certifications cover the 48xx Series thermal mass flow devices as well as the Local Operator Interface (LOI).

Mark	Agency	Certification/ Marking/ Directive	Applicable Standard	Details
	CSA	Class I, Div 2 Groups A, B, C & D; T4 Class 1, Zone 2, AEx nA II T4 Ex nA II T4	UL & CSA Standards	Certificate No. 06.CSA150464
	ATEX	II 3 G Ex nA II T4	EN60079-0:2006 EN 60079-15:2005	KEMA 06ATEX0251 X
	CE	EMC Directive 2014/30/EU	EN:61326-1:2013	EMC
		RoHS Directive 2011/65/EU		RoHS
		Pressure Equipment Directive 2014/68/EU		Sound Engineering Practice (SEP)

Hazardous Location Classification

The modules shall be installed in a suitable enclosure providing a degree of protection of at least IP54 according to EN 60529, taking into account the environmental conditions under which the equipment will be used. Provisions shall be made to prevent the rated voltage from being exceeded by transient disturbances of more than 40%.

Code Description	Code Option	Option Description
I. Base Model Number	4850	Flow Controller, Body 0 (50 sccm-40 slpm)
	4860	Flow Meter, Body 0 (50 sccm-40 slpm)
II. Digital I/O Communications	A	RS-232 + Analog, Select applicable analog I/O
III. Model Revision Level	B	Revision
IV. Analog I/O, Input / Output	B	0-5 Vdc / 0-5 Vdc
	C	4-20 mA / 4-20 mA
	D	0-5 Vdc / 4-20 mA
	E	4-20 mA / 0-5 Vdc
	0	None
V. Power Supply	1	15 Vdc
	2	24 Vdc
VI. Mechanical Connections	1A	9/16"-18unf straight thread
	B1	1/4" tube compression w/filter
	C1	1/8" tube compression w/filter
	D1	3/8" tube compression w/filter
	E1	1/4" VCR w/filter
	F1	1/4" VCO w/filter
	G1	1/4" NPT-F w/filter
	H1	6mm tube compression w/filter
	J1	10mm tube compression w/filter
	S1	Downport, no O-ring cavity
	T1	1/4" Rc (BSPT) w/filter
	X1	Downport, with O-ring cavity
	Y1	1/4" tube w/filter (5850TR replace)
VII. Body		Body O-Ring Seal Seat Valve Type
	A	316ss Viton None (Meter Only) None (Meter Only)
B	316ss Viton Viton Normally Closed	
VIII. Area Classification	1	Standard Location (Safe Area)
	2	ATEX Zone 2
	4	CSA Div 2/Zone 2 (Recognized)
IX. Valve Orifice Size	A	No Orifice (Meter Only)
	B	0.001 inch / 0.03mm
	C	0.002 inch / 0.05mm
	D	0.003 inch / 0.08mm
	E	0.005 inch / 0.125mm
	F	0.008 inch / 0.2mm
	G	0.012 inch / 0.315mm
	H	0.020 inch / 0.5mm
	J	0.031 inch / 0.8mm
	K	0.049 inch / 1.25mm only available with power supply option code=2 (24 Vdc)

Code Description	Code Option	Option Description		
X. Mass Flow Restrictor Type		Type or Restrictor	Restrictor Range (sccm N ₂ Equivalent @ 0 Deg C ref)	
	A	No Restrictor	NA	NA
	C	Plug	0	180
	K	K	160.4	228.53
	M	M	218.4	310.6
	N	N	265.7	377.7
	P	P	332	471.6
	Q	Q	424.8	603
	R	R	554.8	787
	S	S	736.7	1044.6
	T	T	991.4	1405
	U	U	1348	1910
	V	V	1847	2617
	W	W	2546	3607
	X	X	3524	4992
	Y	Y	4894	6932
	1	1	6811	9647
2	2	9496	13,453	
3	3	13,250	18,773	
4	4	18,520	30,143	
5	5	30,100	50,143	
XI. Calibration		Calibration Condition	Accuracy	Tracability
	A	None-Uncalibrated	NA	NA
	B	Single Gas	+/- 3.0% of FS	None
	C	Single Gas	+/- 1.0% of FS	None
	D	Single Gas	+/- 1.0% of FS	NIST
E	Single Gas	+/- 1.0% of FS	CMC Cert. (NMI)	
XII. Accessories	0	None		
	1	LOI with Power Adapter		
	2	LOI without Power Adapter		
XIII. Certificates	0	None		
	9	Multiple Certs. Describe required certs in notes. Add all applicable changes to list price.		
	A	Declaration of Compliance 2.1 (Certificate of Conformance)		
	B	Declaration of Compliance 2.1 Leak Test		
	C	Declaration of Compliance 2.1 Pressure Test		
	D	Declaration of Compliance 2.1 Oxygen Service		
E	Declaration of Compliance 2.1 Materials			
XIV. OEM Code	A	Standard Brooks Label		

Sample Model Code

I	II	III	IV	V	VI	VII	VIII	IX	X	XI	XII	XIII	XIV
4850	A	B	B	1	1A	A	2	D	K	E	2	9	A

Request a Quote

Service and Support

Brooks is committed to assuring all of our customers receive the ideal flow solution for their application, along with outstanding service and support to back it up. We operate first class repair facilities located around the world to provide rapid response and support. Each location utilizes primary standard calibration equipment to ensure accuracy and reliability for repairs and recalibration and is certified by our local Weights and Measures Authorities and traceable to the relevant International Standards.

Visit www.BrooksInstrument.com to locate the service location nearest to you.

START-UP SERVICE AND IN-SITU CALIBRATION

Brooks Instrument can provide start-up service prior to operation when required. For some process applications, where ISO-9001 Quality Certification is important, it is mandatory to verify and/or (re)calibrate the products periodically. In many cases this service can be provided under in-situ conditions, and the results will be traceable to the relevant international quality standards.

CUSTOMER SEMINARS AND TRAINING

Brooks Instrument can provide customer seminars and dedicated training to engineers, end users, and maintenance persons.

Please contact your nearest sales representative for more details.

Due to Brooks Instrument's commitment to continuous improvement of our products, all specifications are subject to change without notice.

TRADEMARKS

BrooksBrooks Instrument, LLC

All other trademarks are the property of their respective owners.



DS-TMF-4800-MFC-eng/2017-1



Av. Dr. Lino de Moraes Leme, 1.094
Vila Paulista – São Paulo/SP - 04360-000.
+55 11 5035-0920 | 11 2935-5310
atendimento@contechind.com.br