

Sho-Rate™ Models 1350G & 1355G

Glass Tube Variable Area Flowmeters (Rotameters)
for Low Flow Rates

Sho-Rate™ Series glass tube variable area flowmeters have been the industry standard for decades. Ideal for a variety of low flow gas and liquid applications, these flowmeters are particularly suited for purge applications. The base configuration uses a borosilicate glass tube installed in an aluminum frame with 316SS end blocks, adaptors, and valve. Additional material options, valve options, and flow controllers are available to provide the appropriate configuration for a wide variety of applications.



Features

Benefits

Standard Direct Read Scales on Tube and Millimeter Scales with Flow Data for All Fluids and Fluid Conditions	Tube and float options to meet exact customer process conditions
Multiple Connection Fittings, Adapters, and Approval Certifications	Suits a wide range of world area applications and requirements
Clear Polycarbonate Face Shield with Built-In Magnifier	Easier float and scale reading
Heavy Wall, Precision Bore Borosilicate Glass Metering Tube	Resistant to thermal shock and corrosive gasses and fluids
Integrated Alarm Option with Single or Double Inductive Ring Sensor/Switch with Intrinsically Safe Relay	Ideal for hazardous environments and applications where process conditions are critical
Interchangeable Tubes and Floats with Integral Float Stops	Easy in-situ maintenance. Prevents loss of float during tube removal
Compatible with Cartridge and Precision Control Valve (Inlet & Outlet) and Integral Flow Controller (Upstream & Downstream)	Meets a wider range of customer requirements where flow control is necessary

Product Specifications

	1350G	1355G
Performance		
Accuracy	±5% at reference conditions*	±3% at reference conditions*
Repeatability	0.25% F.S.	
Pressure / Temperature	200 psig (33°F - 250°F) / 13.8 bar (1°C - 121°C)	
Materials of Construction	Borosilicate glass, Brass, Aluminum, 316 Stainless Steel, Clear Polycarbonate, Milk White Polycarbonate, Teflon®	
End Block Options	Stainless Steel and Brass	
Elastomer Seals	Viton® fluoroelastomers, Teflon®, Buna, Kalrez® per fluoroelastomers	
Float Materials	Glass, Sapphire, Stainless Steel, Carboloy®, Tantalum	
Connection Materials	Stainless Steel	
Connection Options	1/8" NPT (w/wo locknuts) 1/4" NPT (w/wo locknuts) 1/8" Compression (w/wo locknuts) 1/4" Compression (w/wo locknuts) 6 mm Compression (w/wo locknuts) 1/4" RC (w/wo locknuts) 3/8" RC (w/wo locknuts) 1/4" VCR® 1/4" ID Hose	
Dimensions	See Dimension Drawings	
Alarm Availability	1 Inductive Ring Sensor/Switch 2 Inductive Ring Sensor(s)/Switch(es) Inductive Ring Sensor(s)/Switch(es) with Relay Options	
Valve Options	Cartridge III Valve and NRS™	
Valve Materials	Stainless Steel	
Flow Controller	Yes	
Certifications	International Calibration Certificate (ICC) CRN Pressure Equipment Directive (97/23/EC) RoHS (II) REACH Materials (2.1)	

* Reference conditions apply to air or water at 14.7 psia and 70 Degrees F/1.01 Bar and 21.1 Degrees C.

Product Specifications

Capacities - Rib Guide Tubes, Spherical Floats for use with 1350G Series Only

Meter Size	Tube No.	Float Material	Full Scale - Water		Full Scale - Air	
			GPH	LPH	SCFH ¹	NLPH ²
2	R-2-65-A G	Glass	0.010	0.041	0.12	3.2
		Sapphire	0.021	0.079	0.19	5.0
		Stainless Steel	0.049	0.18	0.37	9.8
		Carboloy	0.10	0.36	0.65	17
		Tantalum	0.10	0.40	0.71	18
	R-2-65-B G	Glass	0.014	0.06	0.16	4.4
		Sapphire	0.028	0.10	0.25	6.7
		Stainless Steel	0.07	0.25	0.48	12
		Carboloy	0.12	0.48	0.80	21
		Tantalum	0.14	0.53	0.87	22
	R-2-65-C G	Glass	0.12	0.47	0.99	26
		Sapphire	0.22	0.83	1.3	35
		Stainless Steel	0.41	1.5	2.1	55
		Carboloy	0.65	2.4	3.1	81
		Tantalum	0.70	2.6	3.3	87
	R-2-65-D G	Glass	0.68	2.5	3.9	100
Sapphire		0.99	3.7	5.1	130	
Stainless Steel		1.6	6.3	7.9	200	
Carboloy		2.5	9.5	11	290	
Tantalum		2.7	10.0	12	310	
6	R-6-65-A G	Glass	2.2	8.5	13	340
		Sapphire	3.3	12	17	440
		Stainless Steel	5.6	21	25	660
		Carboloy	8.3	31	36	940
		Tantalum	8.8	33	38	1000
	R-6-65-B G	Glass	8.7	33	46	1200
		Sapphire	12	47	59	1500
		Stainless Steel	20	76	86	2200
		Carboloy	29	100	110	3100
		Tantalum	30	110	120	3300

¹ Air flow rates in standard units are at 70°F & 14.7 PSIA. Reference conditions 70°F latm.

² Air flow rates in normal units are at 20°C & 1.013 bar. Reference conditions 0°C latm.

Product Specifications

Capacities - Rib Guide Tubes, Spherical Floats for use with 1355G Series Only

			Full Scale Flow	
Meter Size	Tube No.	Float Material	Water (CC/Min)	Air ¹
2	R-2-15-AAAA G	Glass	0.59	50 SCC/M
		Sapphire	1.1	79 SCC/M
		Stainless Steel	2.6	150 SCC/M
		Carboloy	5.2	280 SCC/M
		Tantalum	5.8	310 SCC/M
	R-2-15-D G	Glass	5.5	370 SCC/M
		Sapphire	10	520 SCC/M
		Stainless Steel	20	830 SCC/M
		Carboloy	34	1200 SCC/M
		Tantalum	36	1300 SCC/M
	R-2-15-A G	Glass	17	0.82 SLPM
		Sapphire	26	1.0 SLPM
		Stainless Steel	46	1.6 SLPM
		Carboloy	70	2.4 SLPM
		Tantalum	75	2.5 SLPM
	R-2-15-B G	Glass	53	2.3 SLPM
		Sapphire	80	3.0 SLPM
		Stainless Steel	130	4.6 SLPM
		Carboloy	200	6.7 SLPM
		Tantalum	210	7.1 SLPM
R-2-15-C G	Glass	90	4.0 SLPM	
	Sapphire	130	5.2 SLPM	
	Stainless Steel	220	7.9 SLPM	
	Carboloy	340	11 SLPM	
	Tantalum	360	11 SLPM	
6	R-6-15-A G	Glass	210	9.5 SLPM
		Sapphire	320	12 SLPM
		Stainless Steel	540	18 SLPM
		Carboloy	790	25 SLPM
		Tantalum	840	26 SLPM
	R-6-15-B G	Glass	560	23 SLPM
		Sapphire	820	29 SLPM
		Stainless Steel	1300	43 SLPM
		Carboloy	1900	60 SLPM
		Tantalum	2000	63 SLPM

¹ Air flow rates in standard units are at 70°F & 14.7 PSIA. Reference conditions 70°F latm.

Product Dimensions

Model 1350G

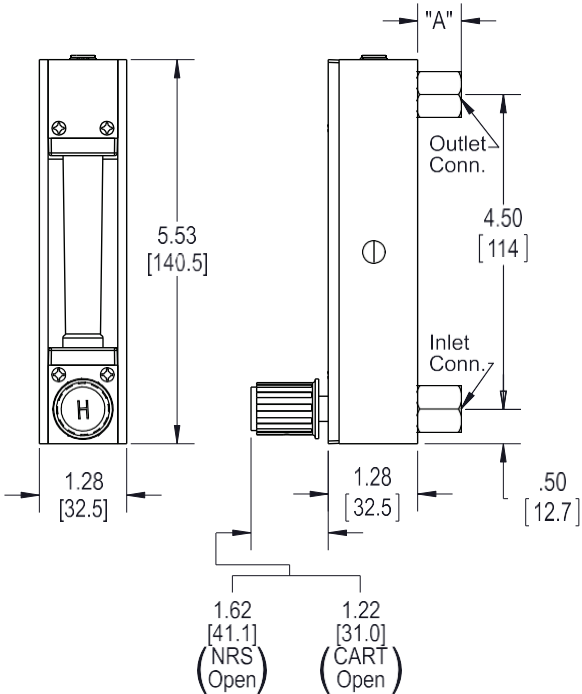

Dimension "A" Connection Adapter

1/8" NPT	0.625 [15.9]
1/4" NPT	0.625 [15.9]
1/8" Compression	1.59 [40.3]
1/4" Compression	1.78 [45.1]
1/4" ID Hose	0.72 [18.3]
1/4" RC	0.895 [22.7]
3/8" RC	0.895 [22.7]

Model 1355G

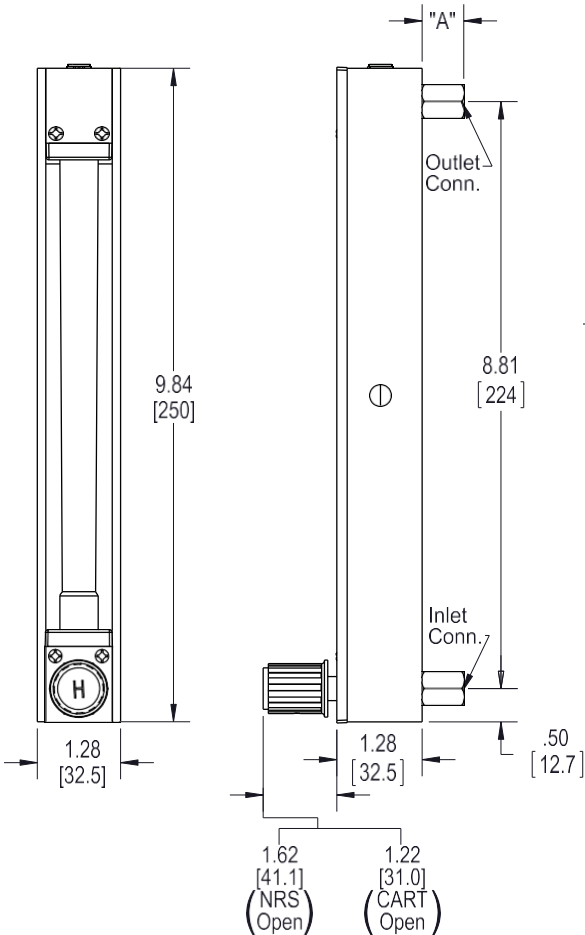

Dimension "A" Connection Adapter

1/8" NPT	0.625 [15.9]
1/4" NPT	0.625 [15.9]
1/8" Compression	1.59 [40.3]
1/4" Compression	1.78 [45.1]
1/4" ID Hose	0.72 [18.3]
1/4" RC	0.895 [22.7]
3/8" RC	0.895 [22.7]

Model 1350G/1355G with Model 8800 Flow Controller on Inlet

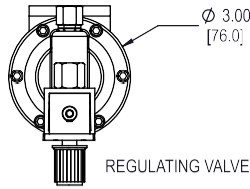

Model No.	Scale Length	Dim A		Dim B		Dim C (Open)		Dim C (Closed)		Dim D	
		mm	Inch	mm	Inch	mm	Inch	mm	Inch	mm	mm
1350	65	7.31	185.7	4.34	110.3	2.79	70.8	2.65	67.2	6.38	162.0
1355	150	11.72	297.7	8.75	222.2	2.79	70.8	2.65	67.2	10.78	273.8

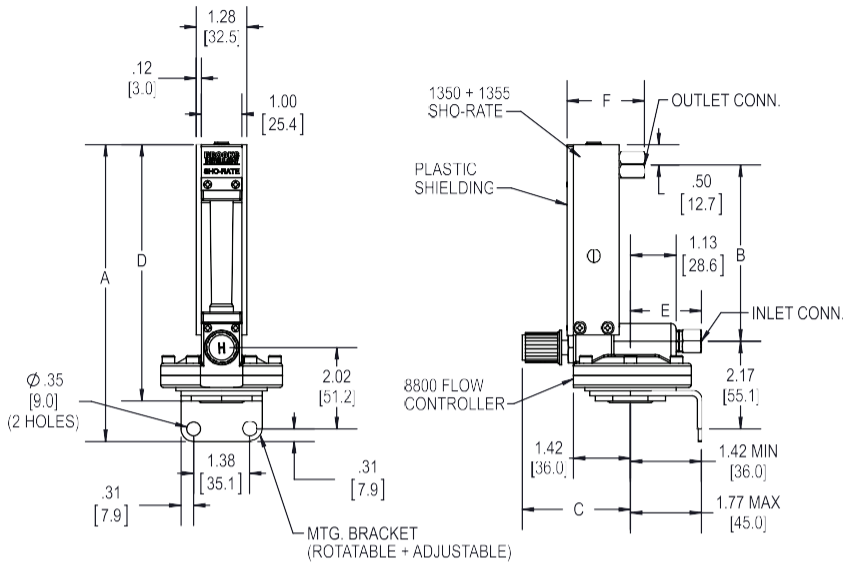

Conn. Size	Inlet Connection		Outlet Connection	
	E	F	E	F
1/8 NPT	1.85	46.9	1.91	48.4
1/4 NPT	1.13	28.6	1.91	48.4
1/8 Comp.	2.19	55.6	2.87	72.8
1/4 Comp.	2.28	57.8	3.06	77.6
1/4 ID Hose	2.44	61.9	2.00	50.8
1/4 VCR (M)	N/A	N/A	2.19	55.6
1/4 RC	2.10	53.3	2.18	55.3
3/8 RC	2.60	66.1	2.18	55.3

Model 1350G/1355G with Model 8900 Flow Controller on Outlet

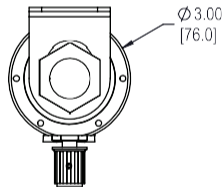

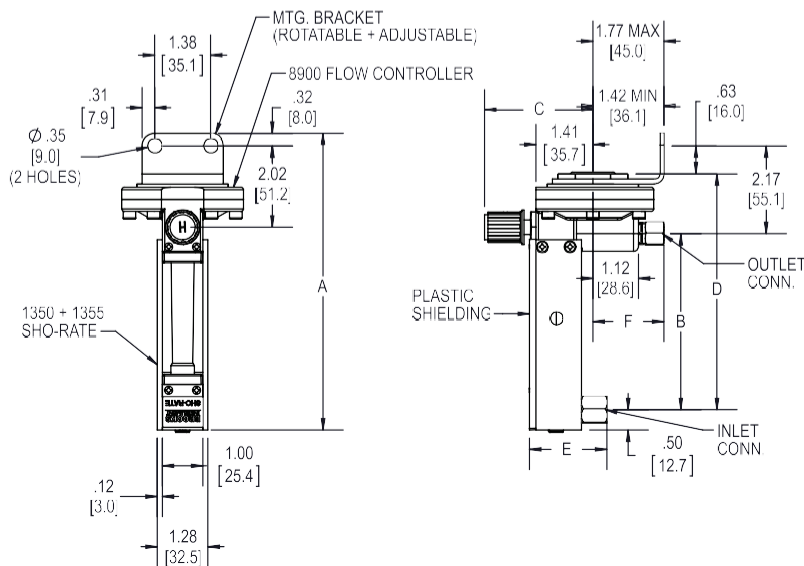

Model No.	Scale Length	Dim A		Dim B		Dim C (Open)		Dim C (Closed)		Dim D	
		mm	Inch	mm	Inch	mm	Inch	mm	Inch	mm	mm
1350	65	7.31	185.7	4.34	110.3	2.79	70.8	2.65	67.2	6.38	162.0
1355	150	11.72	297.7	8.75	222.2	2.79	70.8	2.65	67.2	10.78	273.8



Conn. Size	Inlet Connection		Outlet Connection	
	E	F	E	F
1/8 NPT	1.91	48.4	1.85	46.9
1/4 NPT	1.91	48.4	1.13	28.6
1/8 Comp.	2.87	72.8	2.19	55.6
1/4 Comp.	3.06	77.6	2.28	57.8
1/4 ID Hose	2.00	50.8	2.44	61.9
1/4 VCR (M)	2.19	55.6	N/A	N/A
1/4 RC	2.18	55.3	2.10	53.3
3/8 RC	2.18	55.3	2.60	66.1

Product Approvals

Declaration	Mark	Meter Options	Standards/Directives/Marking	Status/Certificate
		Inductive Alarm		
EU Declaration of Conformity		✓	EMC Directive (2014/30/EU)	Declaration
		✓	RoHS Directive (2011/65/EU)	Declaration
		✓	Pressure Equipment Directive (2014/68/EU)	Declaration
		✓	EMC Directive (2014/30/EU)	Declaration
Explosion safety "Intrinsic Safety (ia)"		✓	Inductive Ring Sensor Pepperl + Fuchs Model: RC10-14-N3-Y53478 Pepperl + Fuchs Model: RC15-14-N3-Y53479 <u>Non-Hazardous Locations</u> Power Supply Nominal Voltage 8V Operating Voltage 5...25V Current consumption Active area clear : 3mA (at 8V) Active area obscured: 0.5. 0.95mA (at 8V) Ambient Temperature 0°C to 40°C	Pepperl + Fuchs PTB 99 ATEX 2128 X
		✓	<u>Hazardous Location</u> ATEX II 2 G Ex ia IIC T6...T1 Gb IP67 Refer to ATEX Certificate for: Input parameters, Max Ambient Temperature, Special conditions for use	
		✓	FM Approvals Class I, Division 1, Group A, B, C, Class II, Division Group E, F, G, Class III, Division 1 Class I, Zone 0, Group IIC T6	
		✓	Canadian Registration Number (CRN)	CRN

Model Code

Code Description	Code Option	Option Description		
I-IV. Basic Model Number	1350	65mm Sho-Rate Size 1-6 Flow Indicator		
	1355	150mm Sho-Rate Size 1-6 Flow Indicator		
V. Model Revision Level	G	Revision G		
VI. End Block Material	A	316 stainless steel		
	B	Brass		
VII. Tube		1350	1355	
	A	---	R-2-15-A G	
	B	---	R-2-15-B G	
	C	---	R-2-15-C G	
	D	---	R-2-15-D G	
	E	---	R-6-15-A G	
	F	---	R-6-15-B G	
	G	R-2-65-A G	R-2-15-AAAA G	
	H	R-2-65-B G	---	
	J	R-2-65-C G	---	
	K	R-2-65-D G	---	
	L	R-6-65-A G	---	
	M	R-6-65-B G	---	
	N'	No Tube	No Tube	
	VIII-IX. Float & Direct Read Scale Selection		Float	Accuracy
ZZ ^s		None	N/A	N/A
1A		GLASS	STD-50(10%), 55(5%)	MM
1B		ST.STL	STD-50(10%), 55(5%)	MM
1C		SAPPHIRE	STD-50(10%), 55(5%)	MM
1D		CARBOLOY	STD-50(10%), 55(5%)	MM
1E		TANTALUM	STD-50(10%), 55(5%)	MM
1G		GLASS	CALIB-50(5%), 55(3%)	MM
1H		ST.STL	CALIB-50(5%), 55(3%)	MM
1J		SAPPHIRE	CALIB-50(5%), 55(3%)	MM
1K		CARBOLOY	CALIB-50(5%), 55(3%)	MM
1L		TANTALUM	CALIB-50(5%), 55(3%)	MM
2A		GLASS	STD-50(10%), 55(5%)	LINEAR
2B		ST.STL	STD-50(10%), 55(5%)	LINEAR
2C		SAPPHIRE	STD-50(10%), 55(5%)	LINEAR
2D		CARBOLOY	STD-50(10%), 55(5%)	LINEAR
2E		TANTALUM	STD-50(10%), 55(5%)	LINEAR
2G		GLASS	CALIB-50(5%), 55(3%)	LINEAR
2H		ST.STL	CALIB-50(5%), 55(3%)	LINEAR
2J		SAPPHIRE	CALIB-50(5%), 55(3%)	LINEAR
2K		CARBOLOY	CALIB-50(5%), 55(3%)	LINEAR
2L		TANTALUM	CALIB-50(5%), 55(3%)	LINEAR
3A		GLASS	STD-50(10%), 55(5%)	CUSTOM DECAL
3B		ST.STL	STD-50(10%), 55(5%)	CUSTOM DECAL
3C		SAPPHIRE	STD-50(10%), 55(5%)	CUSTOM DECAL
3D		CARBOLOY	STD-50(10%), 55(5%)	CUSTOM DECAL
3E		TANTALUM	STD-50(10%), 55(5%)	CUSTOM DECAL
3G		GLASS	CALIB-50(5%), 55(3%)	CUSTOM DECAL
3H		ST.STL	CALIB-50(5%), 55(3%)	CUSTOM DECAL
3J		SAPPHIRE	CALIB-50(5%), 55(3%)	CUSTOM DECAL
3K		CARBOLOY	CALIB-50(5%), 55(3%)	CUSTOM DECAL
3L		TANTALUM	CALIB-50(5%), 55(3%)	CUSTOM DECAL
4A		GLASS	STD-50(10%), 55(5%)	PERCENT SCALE
4B		ST.STL	STD-50(10%), 55(5%)	PERCENT SCALE
4C		SAPPHIRE	STD-50(10%), 55(5%)	PERCENT SCALE
4D		CARBOLOY	STD-50(10%), 55(5%)	PERCENT SCALE
4E		TANTALUM	STD-50(10%), 55(5%)	PERCENT SCALE
4G		GLASS	CALIB-50(5%), 55(3%)	PERCENT SCALE
4H		ST.STL	CALIB-50(5%), 55(3%)	PERCENT SCALE
4J		SAPPHIRE	CALIB-50(5%), 55(3%)	PERCENT SCALE
4K	CARBOLOY	CALIB-50(5%), 55(3%)	PERCENT SCALE	
4L	TANTALUM	CALIB-50(5%), 55(3%)	PERCENT SCALE	

Model Code

Code Description	Code Option	Option Description	
X. Tube Packing and O-ring Materials Note: If valve assy is not required for a specific model number, select the proper code for the O-ring material of the Sho-Rate.		Tube Packing	O-ring Meter/Valve
	A	Buna	Buna
	B	Viton	Viton
	D	Viton	EPR
	E	Viton	Kalrez
	F	Teflon	Buna
	G	Teflon	Viton
	J	Teflon	EPR
	K	Teflon	Kalrez
	L	EPR	EPR
	N	No Packing	Buna
	P	No Packing	Viton
	R	No Packing	EPR
	S	No Packing	Kalrez
T	No Packing	Butyl	
XI. End Fitting Material, Connection Size & Type		Fitting Material	Connection Size and Type
	C	316SS	1/8" NPT
	F	316SS	1/8" NPT Thd.W/Locknut
	J	316SS	1/4" NPT
	N	316SS	1/4" NPT Thd.W/Locknut
	R	316SS	1/8" Compression
	U	316SS	1/8" Compression w/locknut (2 pc design)
	W	316SS	1/4" F-Rc Thd w/Locknut
	X	316SS	1/4" Compression
	1	316SS	1/4" Compression w/locknut (2 pc design)
	3	316SS	3/8" F-Rc Thd w/Locknut
	4 ¹	316SS	1/4" I.D. Hose
	5 ¹	316SS	1/4" I.D. Hose w/Locknut
	6	316SS	Integral 5/16-24 thd.
7	316SS	1/4" VCR	
8 ¹	316SS	6mm Compression	
XII. Valve Type	A	Valve Plug	
	B	NRS-316SS #1	
	C	NRS-316SS #2	
	D	NRS-316SS #3	
	E	NRS-316SS #4	
	F	NRS-316SS #5	
	G	NRS-316SS #6	
	N	To Integrally Mounted 88/8900 316SS Flow Controller - Cartridge II/III Valve - Teflon Diaphragm	
	P	To Integrally Mounted 88/8940 316SS Flow Controller - NRS Valve - Teflon Diaphragm	
	Q	To Integrally Mounted 88/8900 Brass Flow Controller - Cartridge II/III Valve - Buna Diaphragm	
	R	To Integrally Mounted 88/8940 Brass Flow Controller - NRS Valve - Buna Diaphragm	
	S	Std. Valve Cavity - no valve assy or plug	
	T	Cartridge III Valve - Low Flow - 316SS	
	U	Cartridge III Valve - Med Flow - 316SS	
V	Cartridge III Valve - HighFlow - 316SS		

Model Code

Code Description	Code Option	Option Description
XIII. Valve Cavity/Controller Location & Connection Orientation		Valve/Controller Location
		Connection Inlet Orientation Outlet
	1	Inlet Back
	5	Outlet Back
XIV. Alarms Note: Alarm options not available with the following: - Glass, Sapphire, or Tantalum Floats - Stainless Steel Frame Option - Valve Type Option: Flow Controllers	A	None
	B	1 Inductive Ring Sensor/Switch
	C	2 Inductive Ring Sensors/Switches
	D	1 Inductive Ring Sensor/Switch w/I.S. Relay 120V (bistable)
	E	1 Inductive Ring Sensor/Switch w/I.S. Relay 240V (bistable)
	F	2 Inductive Ring Sensors/Switches with I.S. Double Relays 120V (bistable)
	G	2 Inductive Ring Sensors/Switches with I.S. Double Relays 240V (bistable)
XV. Options	A	None
	B	316 Stainless Steel Frame
	C	Baseplate (Plastic Triangle Base with Aluminum Bracket)
	D	No Brooks Identification
	E	316SS Frame & No Brooks ID
	F	Baseplate & No Brooks ID
	G	316SS Frame & Baseplate
	H	316SS Frame & Baseplate & No Brooks ID
	J	Stainless Steel Tag & 316SS Frame
	K	Stainless Steel Tag & Baseplate (Aluminum)
	L	Stainless Steel Tag & no Brooks ID
	M	Stainless Steel Tag & 316SS Frame & No Brooks ID
	N	Stainless Steel Tag & Baseplate & No Brooks ID
	P	Stainless Steel Tag & 316SS Frame & Baseplate
	Q	Stainless Steel Tag & 316SS Frame & Baseplate & No Brooks ID
	R	Stainless Steel Tag
	S	Stainless Steel Float Stops
T	Open Alarm Frame	
U	316SS Frame & Stainless Steel Float Stops	
XVI. Certifications	A	None
	B	CRN Certification
	C	International Calibration Certification (5%-1350, 3%-1355)
	D	Degrease for Oxygen Service (not MIL Spec)
	E	CRN Cert & ICC
	F	CRN Cert & Degrease for O ₂
	G	Degrease for O ₂ & ICC
	H	CRN Cert, ICC & Degrease for O ₂

¹ The options indicated are not available with a CRN certification. Not valid for controllers.

² Accuracy for air and water in the preceding capacity tables will be STD-50(5%), 55(3%).

³ Use this code (ZZ) only when Tube Code above is "N"

Sample Standard Model Code

IV	V	VI	VII	VIII-IX	X	XI	XII	XIII	XIV	XV	XVI
1350	G	A	G	1B	E	C	A	1	A	A	A

Brooks is committed to assuring all of our customers receive the ideal flow solution for their application, along with outstanding service and support to back it up. We operate first class repair facilities located around the world to provide rapid response and support. Each location utilizes primary standard calibration equipment to ensure accuracy and reliability for repairs and recalibration and is certified by our local Weights and Measures Authorities and traceable to the relevant International Standards.

Visit www.BrooksInstrument.com to locate the service location nearest to you.

START-UP SERVICE AND IN-SITU CALIBRATION

Brooks Instrument can provide start-up service prior to operation when required. For some process applications, where ISO-9001 Quality Certification is important, it is mandatory to verify and/or (re)calibrate the products periodically. In many cases this service can be provided under in-situ conditions, and the results will be traceable to the relevant international quality standards.

SEMINARS AND TRAINING

Brooks Instrument can provide seminars and dedicated training to engineers, end users, and maintenance persons. Please contact your nearest sales representative for more details.

Due to Brooks Instrument's commitment to continuous improvement to four products, all specifications are subject to change without notice.

TRADEMARKS

Brooks, NRS, Sho-Rate.....Brooks Instrument, LLC

All other trademarks are the property of their respective owners.

Data-Sheet-1350G-EN/2025-01



The logo for Contech, featuring the word "Contech" in a bold, italicized, sans-serif font with a horizontal line under the "t".

Av. Dr. Lino de Moraes Leme, 1.094
Vila Paulista – São Paulo/SP – 04360-000.

+55 11 5035-0920

Atendimento@contechind.com.br

www.contechind.com.br